

INON

Quick Shoe W95 Plate

- Package contents :**
- W95 Plate ×1
 - W95 Plate Body ① ×1
 - 1/4-20UNC Cap Screw (L12.5) ② ×2
 - M6 Washer ③ ×2
 - Allen Wrench 3/16 inch ④ ×1
 - This user manual ×1

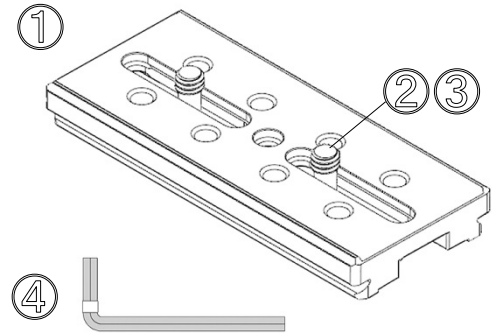

- Compatible products:**
- [Quick Shoe]**
- Quick Shoe W50 Clamp
 - Quick Shoe W27 Clamp
 - Quick Shoe Main Base

- Compatible products:**
- [Housing]**
- INON X-2 series housing
 - Other brands' housings * **

- Compatible products:**
- [Arm Base]**
- Grip Base D5
 - Quick Shoe Main Base
 - Other brands' arm base * **

* Two 1/4 inch screw holes with center-to-center distance of 20 – 80 mm/0.8 – 3.1 inch are required to install this product.

** INON INC. has not confirmed compatibility with specific product(s) from other manufactures. Before using, be sure to check if the product from other manufacture is attachable and does not interfere other combined product(s).

- Compatible products:**
- [Arm System]**
- Multi Direct Base IIa, Multi Direct Base II Long
 - Multi Direct Base II WB

Installation:

Place the **W95 Plate** on to a combined product so that slotted holes of the **W95 Plate** match with tripod screw holes of the combined product and partially/evenly tighten pre-installed 1/4-20UNC Cap Screws by supplied **Allen Wrench 3/16 inch**. Check/adjust **W95 Plate** position and completely tighten the 1/4-20UNC Cap Screws.

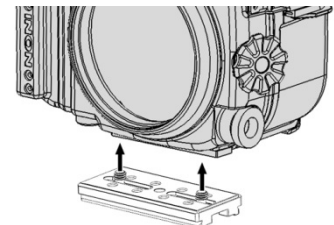

Slotted holes' ends have **1/4-20UNC threads** as per the right illustration to use when removing pre-installed 1/4-20UNC Cap Screw.

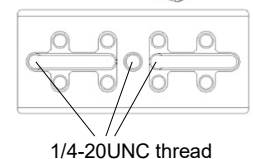

Installing: Arm System

Top panel of the **W95 Plate** is equipped with **M6 threaded holes** to attach variety of adapters.

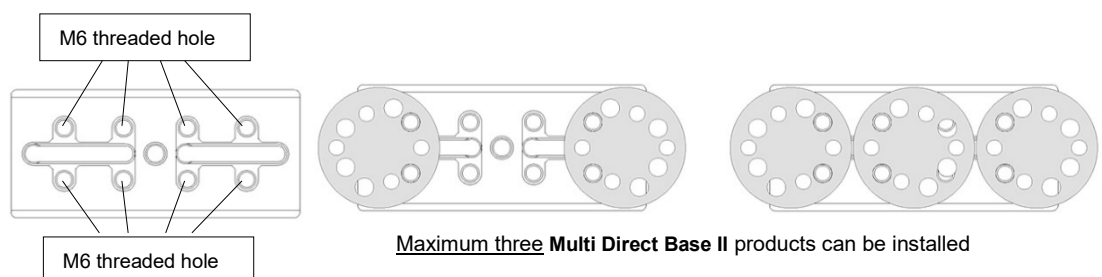

INON INC. 2-18-9, Dai, Kamakura, Kanagawa 247-0061 JAPAN
E-mail support@inon.co.jp, Fax +81(0)467-48-2178
URL <http://www.inon.jp/> As of September 2020