

INON

INON Quick Base M6W

Thank you for purchasing INON product.

INON "Quick Base M6W" is a key component of "Quick Holder System" equipped with YS mount adapter, two of male slides to carry maximum two of INON "Quick Holder LF/LE/Z" and compatible INON strobe or action camera accessory on the top.

- Package contents:**
- Quick Base M6W ① ×1
 - M8 Thumbscrew ② ×1
 - Allen Wrench (WAF: 5mm) ③ ×1
 - This user manual ×1

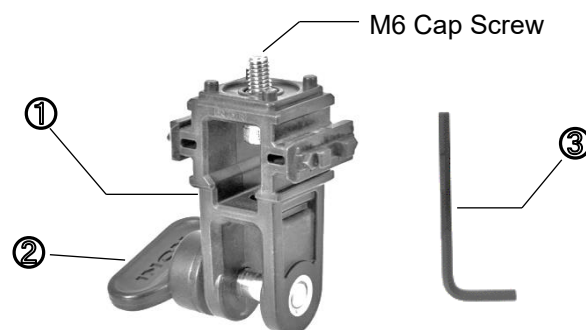

Compatible Products:
(as of July 2019)

[Compatible Quick Holder]

- INON "Quick Holder LF", "Quick Holder LE", "Quick Holder Z",

[Compatible strobe]

- INON "Z-330", "D-200", "S-2000", "Z-240", "D-2000", "D-2000S", "D-2000W/Wn"

[Compatible Front Mask/Mount Base]

- INON "SD Front Mask for HERO5/6/7", "SD Front Mask STD", "SD Mount Base UWH1", "SD Mount Base for TG-Tracker"

[Compatible YS Mount arm]

- INON "Shoe Base II", "Direct Base YS RT", "Direct Base YS", "Bar Mount", "Grip Base D4", "Grip Base M1", "D Holder", "D Holder Extension Bar", "YS Adapter MV", "Double YS Adapter MV", "YS Adapter WB MV", "YS Adapter", "YS Arm MS Body", "YS Arm M Body", "Port Arm for MRS", "Port Arm for UFL-MR130 EFS60"

Installation:

① **M6 Cap Screw**

First remove M8 Thumbscrew then install compatible strobe, Front Mask or Mount Base on the top and fasten it by tightening the M6 Cap Screw by supplied Allen Wrench.

② **Quick Mount Slides**

Attach compatible Quick Holder product with LED torch/strobe.

Please refer to [Quick Holder System Installation/Removal] on the next page.

③ **YS Mount**

Remove M8 Thumbscrew and put this product on a YS Mount arm then fasten them with the removed M8 Thumbscrew.

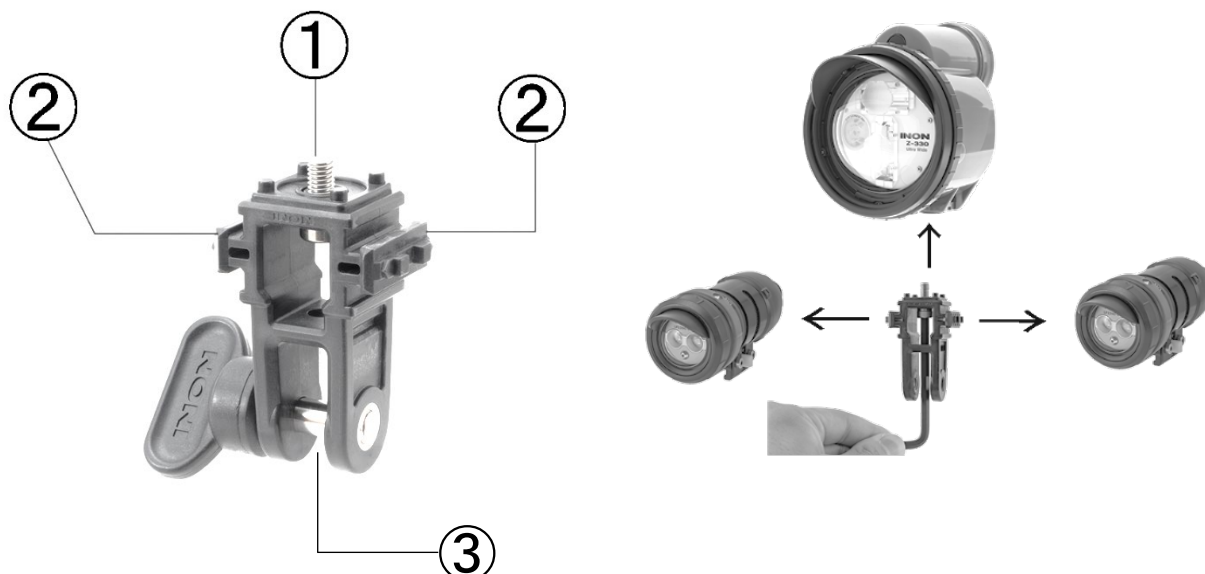

Quick Holder System Installation/Removal

- ① With pressing the Lock Button, insert male slide of the “Quick Base” into female slide of the “Quick Holder”
*Below images shows “Quick Base S” instead of “Quick Base M6W” but how to install/remove Quick Holder product(s) is same.
- ② Release the Lock Button once the “Quick Holder” has come to the lock position as show in center of below images.
Except for lock position, female slide of the “Quick Holder” and male slide of the “Quick Base” won’t be engaged.
- *Before use, make sure that “Quick Holder” and “Quick Base” is securely fastened with lock position.**

①



②

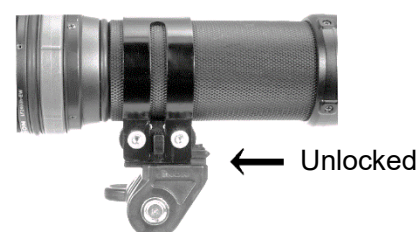
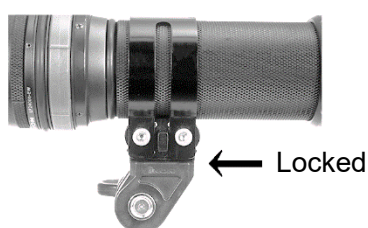

Maintenance:

- After using, soak in fresh water to dissolve remaining salt or remove dirt and dry it in shaded and well ventilated area. Never apply flame or direct heat to this product or damage may result.
- **DO NOT** clean with organic solvent like alcohol, benzene or thinner and oil and fat containing / chemical material like rust inhibitor, lubricant, polish, detergent (especially alkaline detergent) to avoid damage/deformation/degradation of this product (PC part etc.).
- Remove the combined product(s) from this product when not using more than one week to avoid damage/deformation of compatible product(s) resulting from continuous pressure.
- Periodically grease up threaded parts of M8 Thumbscrew, its screw hole and M6 cap screw of this product to prevent anchoring of screws due to salt build-up or electrical corrosion.

Storage:

- Store out of direct sunlight in well-ventilated, dry area. Avoid storing near chemicals, high ozone, large temperature and humidity fluctuations to avoid deformation, damage, rust, mold or corrosion etc.
- Keep the product out of reach of children. They may swallow parts of this product. See a doctor immediately if a child swallow parts.

Handling Precautions:

- When transporting, be sure to hold “whole of camera system” instead holding this product only or combined product (LED torch or strobe etc.) only and **DO NOT** apply excessive shock, vibration or excessive load on the combined system to avoid combined product or this product being fell off/damaged/missing.

INON Quick Base M6W Specifications [*1]	
Model	Quick Base M6W
Size (W x H x D)	46.4× 67.2 ×29mm/1.8 x 2.6 x 1.1in. [*2]
Weight [*2]	61g/2.2 oz (air), approx. 31g/1.1 oz (underwater)
Material	PC, stainless

*1 Specifications are subject to change without prior notice.

*2 Excluding Thumbscrew

INON Inc.
2-18-9, Dai, Kamakura,
Kanagawa 247-0061 JAPAN
E-mail support@inon.co.jp
Fax. +81(0)467-48-2178
URL <http://www.inon.jp/>

July, 2019